

THIS DRAWING IS UNPUBLISHED. RELEASED FOR PUBLICATION, 19 .
 © COPYRIGHT 19 BY AMP INCORPORATED. ALL INTERNATIONAL RIGHTS RESERVED.

LOC		DIST		P		F		REVISIONS		DATE	APPD
G	14							ZONE	LTR	DESCRIPTION	
								D	REV PER	063A-0123-02	07MAR02 JS MS

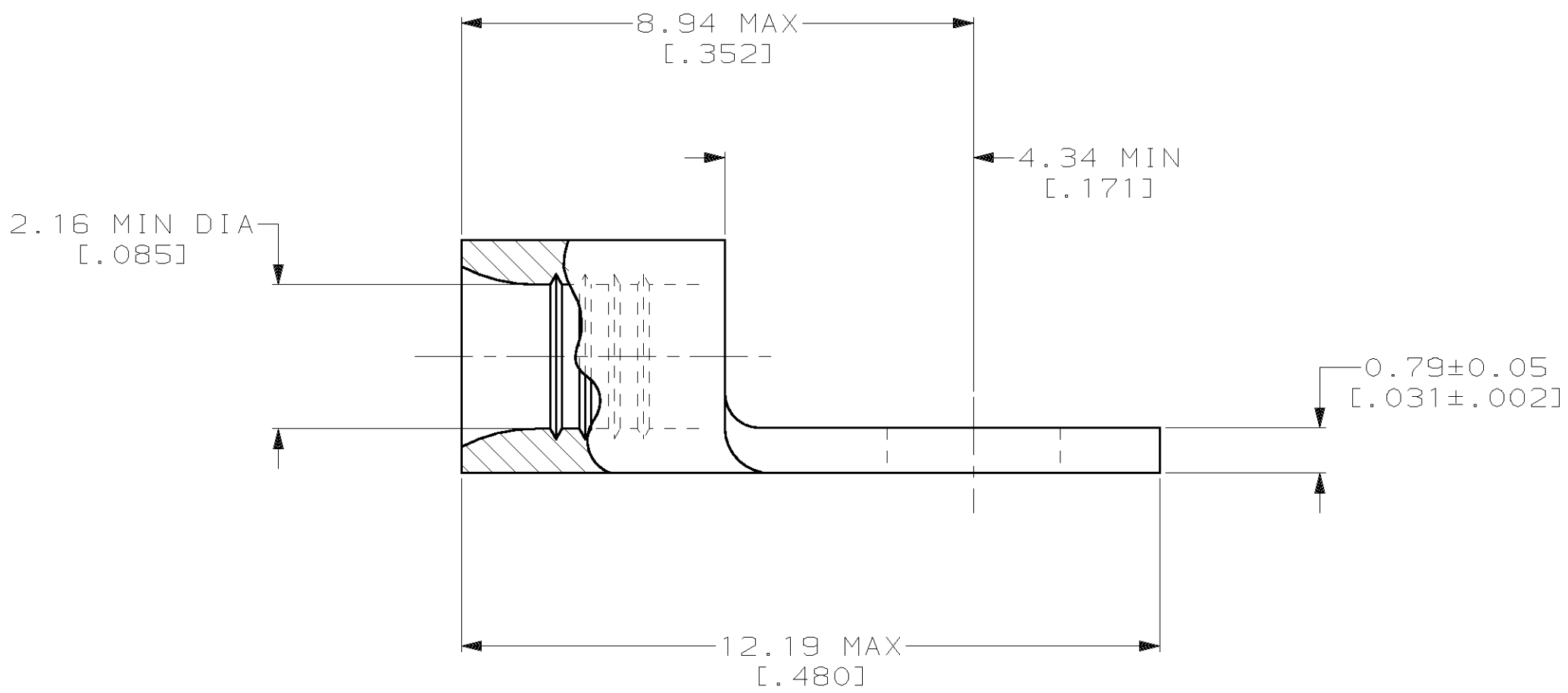
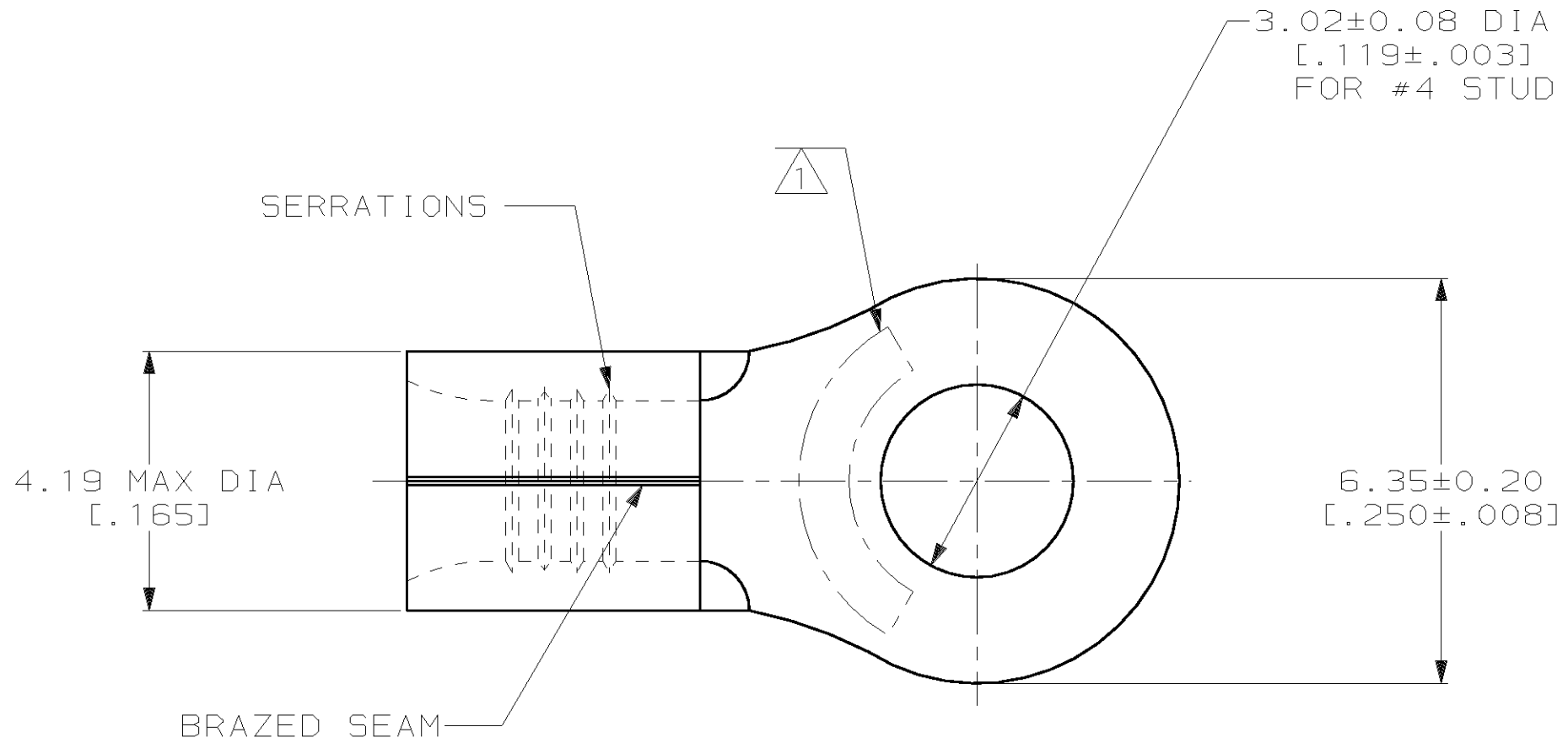

AMP WIRE RANGE	UL E13288 Listed
16-14 AWG SOLID OR STRANDED	16-14 AWG SOLID OR STRANDED
SR LR7189 Certified	MILITARY P/N AND CLASS
16-14 AWG SOLID OR STRANDED	M7928/7-11 CLASS 2 P/N 34119 & 2-34119-1 ONLY

- ① STAMP AMP 16-14* APPROX AS SHOWN
- ② 0.00254 [.000100] MIN TIN PER ASTM B-545.
- ③ CLEANED, UNPLATED

FINISH	QUANTITY	PACKAGING TYPE	PART NO
③	-	LOOSE PIECE	34119-1
②	100	LOOSE PIECE, BOX	8-34119-1
	5000	ON TAPE	2-34119-1
	---	LOOSE PIECE	34119

AMP INCORPORATED
CUSTOMER SERVICE SYSTEMS

FOR ADDITIONAL PRODUCT INFORMATION OR COPIES OF DRAWINGS AND TECHNICAL DOCUMENTS

FOR APPLICATION TOOLING INFORMATION

FOR ORDER ENTRY

PRODUCT INFORMATION CENTER
 1-800-522-6752

TOOLING ASSISTANCE CENTER
 1-800-722-1111

1-800-526-5142

MAX RECOMMENDED OPERATING TEMPERATURE:
 170°C MAX

VOLTAGE RATING:
 NOT APPLICABLE

WIRE CROSS SECTIONAL AREA RANGE:
 1.04-2.62mm² [2,050-5,180] CIR MILS
 SOLID OR STRANDED

THIS DRAWING IS A CONTROLLED DOCUMENT FOR AMP INCORPORATED. IT IS SUBJECT TO CHANGE AND THE CONTROLLING ENGINEERING ORGANIZATION SHOULD BE CONTACTED FOR THE LATEST REVISION.

DO NOT SCALE PRINT. UNLESS SPECIFIED DIMENSIONS IN mm [INCHES] TOLERANCES ON:

2 PLC DEC ± -
 3 PLC DEC ± -
 ANGLES ± -

MATERIAL
 COPPER PER ASTM B-152 ANNEALED

FINISH
 -
 SEE TABLE
 -

DR 3-11-93
 TA BRINKMAN

CHK 3-11-93
 DA PATTERSON

APPD 3-11-93
 DE MILLER

APPD 3-11-93
 JL MECKLEY

PRODUCT SPEC
 -

APPLICATION SPEC
 -

WEIGHT
 -

AMP AMP Incorporated
 Harrisburg, PA 17105-3608

NAME
TERMINAL, RING TONGUE, SOLISTRAND

SIZE
 C

CAGE CODE
 00779

DRAWING NO
 C=34119

SCALE 10:1

SHEET 1 OF 1